

UNLESS OTHERWISE SPECIFIED
DIMENSIONS ARE IN INCHES

SURFACE FINISH:
REMOVED ALL BURRS
AND SHARP EDGES
SURFACE ROUGHNESS

25 ✓

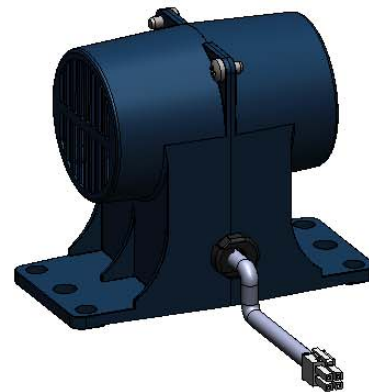
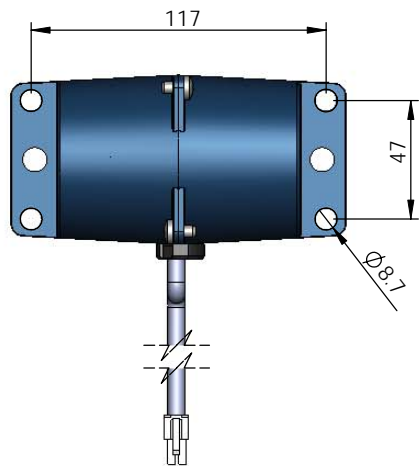

NOTE		
Voltage	120 VAC	220 VAC
Frequency	60 Hz	50 Hz
Roted Amp.	0.4 A	0.3 A
RPM	2150 +/-10%	2300 +/-10%

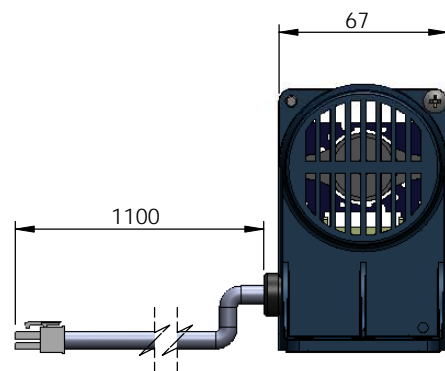
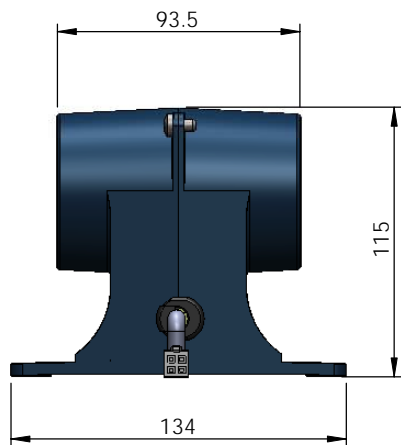

CONFIDENTIAL AND PROPRIETARY

THIS IS THE PROPERTY OF ADACEL.
IT MUST NOT BE TRADED OR REPRODUCED IN ANY MANNER.
NOR SHALL IT BE SUBMITTED TO OUTSIDE PARTIES FOR
EXAMINATION WITHOUT OUR CONSENT. IT SHALL BE USED
AS A MEANS OF REFERENCE TO DO WORK DESIGNED OR
FURNISHED BY US.

MARK	NUMBER	DIVISION	ECO. NO.	SIGNATURE	DATE	MATERIAL	PART NO.	WEIGHT	9	REV.	
							PART NAME	QUANTITY	1	SHEET	1 OF 1
								SCALE	1:10		
DESIGN			Q A				<p>Adacel Technologies Ltd.</p> <p>TOLERANCES ARE: LINEAR 0-2 ±0.2 2-5 ±0.5 5-12 ±0.75 >12 ±1 ANGULAR</p>				
CHECK			APP'VD								
			DATE								